

**Short presentation of the company profile for the
5th call Space in FP7**

**Space Science and Technology
Institute (public institution, capable
fitting to SME frame)
Lithuania**



**COSMOS FP7 Space Information Day
19th July 2011, Riga, Latvia**

Draft Call Topics that we are interested in

Space-based applications at the service of European Society (GMES)

- ***Pre-operational validation of GMES services and products***
 - GMES Security – Support to EU External Actions
 - Support to emergency response management
 - Preparing take-up of GMES Sentinel data
- ***Support to the coordinated provision of observation data***
 - Research and development for In-situ component
 - Climate Change – GMES service coordination – Coordination of Earth observation data validation for re-analysis
 - GMES Climate Change – Data archiving and exchange
 - Consolidation of user requirements for GMES

Strengthening the foundations of Space science and technology (SSF)

- ***Research to support space science and exploration***
 - Exploitation of space science and exploration data
- ***Research to support space transportation and key technologies***
 - Key technologies enabling observations in and from space
 - Key technologies for in-space activities

Cross-cutting activities

- ***SME specific research***
 - Bringing terrestrial SME research into the space domain

Presentation of Space Science and Technology Institute

- Space Science and Technology Institute was established in 2010 by Lithuanian Space Association;
- The purpose of the Institute was to conduct real space researches, take part in the scientific and technical projects and consolidate the scientific potential;
- Institute has worked in fields of space related researches under EU/National projects;
- Institute is interested in wide collaboration with institutions working in space related areas.

Competencies

➤ At the moment Space Science and Technology institute is working in fields of:

1. Nano-Satellite construction:

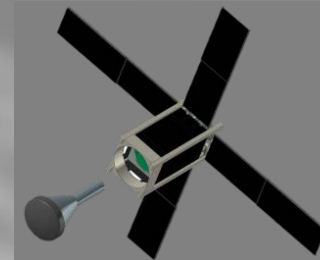

2. Nano-re-entry capsule development;

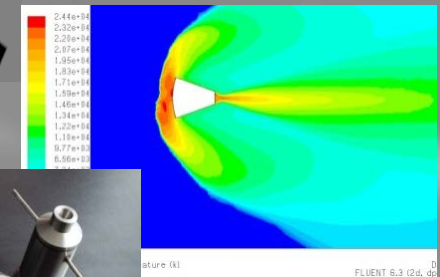

3. Micro-rocket thruster construction;



4. TPS development and testing;

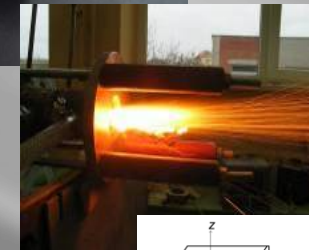

5. Attitude control instrumentation development.

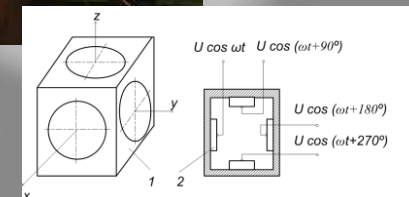

Collaboration

- Space Science and Technology Institute has wide range of connections all over the world (several of them):
 1. Russia – Moscow Lomonosov University; Moscow Aviation Institute; Samara Aerospace University; OKB “Lavochik”; SCKB “Progress”, etc.
 2. Ukraine – Kiev National Aviation University; Dnepropetrovsk national University; KB “Yuzhnoe”, etc.
 3. United States – National Propulsion Laboratory; NASA AMES Center; NASA Goddard Center, etc.
 4. Europe – TU Delft; Alborg TU; TU Berlin; TU Aachen, etc.

Intended Role in a Consortium

- Space Science and Technology Institute:
 - Could be in a role of partner in space related FP7 call;
 - Provide connections both to the Lithuanian and Eastern Europe (Russia, Ukraine, Belarus) universities and organisations;
 - Could act as the coordinator in attitude control system development project (to be highlighted later).

Contact and further information

- Space Science and Technology Institute
- Sauletekio av. 15, LT-10224 Vilnius, Lithuania
- cell: +370 685 67 977 fax: +370 5 2101249
- doibr@kmti.lt, domka@ktv.lt
- www.kmti.lt

**Short presentation of a project proposal for the
5th call Space in FP7**

**„Attitude Control of Micro- and Nanosatellites
Using Multi-degree-of-freedom Piezoelectric
Actuators “**

**Space Science and Technology Institute (public
institution, capable fitting to SME frame)
Lithuania**



**COSMOS FP7 Space Information Day
19th July 2011, Riga, Latvia**

Proposal Aims at

Strengthening the foundations of Space science and technology (SSF)

Cross-cutting activities

➤ ***SME specific research***

➤ Bringing terrestrial SME research into the space domain

➤ ***Studies and events in support of European Space Policy***

➤ New emerging research needs - reduction of vulnerability of space infrastructure

Short outline / Proposal concept I

- Implementation of piezo drives for small spacecraft attitude control equipment:
 1. Dramatically increase the resolution of systems to enable orienting the payload in a precise direction;
 2. Extend the range of allowable temperature to the direction of both positive and negative values;
 3. Significantly reduce the cost and simplify the design;
 4. Increase reliability of orienting systems.

Short outline / Proposal concept II

- Together with Kaunas University of Technology Space Science and Technology Institute would like to initiate or take part in a project of development of satellite attitude control system relying on piezo actuators;
- Entire Piezo actuators implementation idea could consist of several parts:
 1. Single degree of freedom reaction wheel driven by piezo actuators;
 2. Multiple (three) degree of freedom reaction “sphere” driven by piezo actuators;
 3. New principle attitude control instrument relying on the travelling piezo wave principle.

Short outline

- Implementing piezo technologies a variety of reaction instrumentation can be created;
- Flexibility of piezo technology allows constructing reaction equipment with multiple degrees of freedom (which was impossible before).

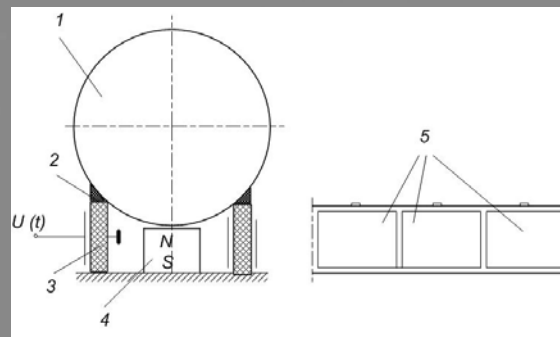
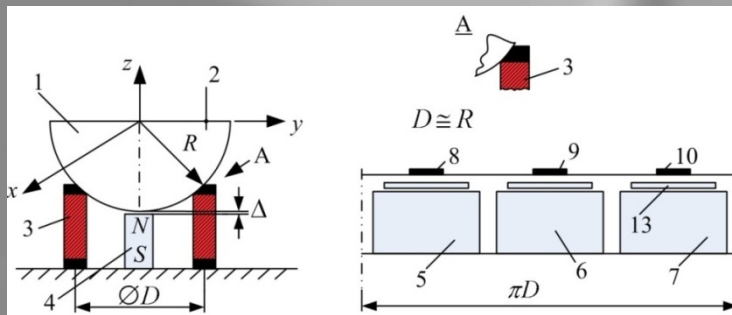

Short outline

- New idea of implementation circular traveling piezo wave for satellite attitude control without the need of rotating mass could be investigated;
- Idea would allow simplifying the structure of satellite thus ensuring extremely precise attitude control.

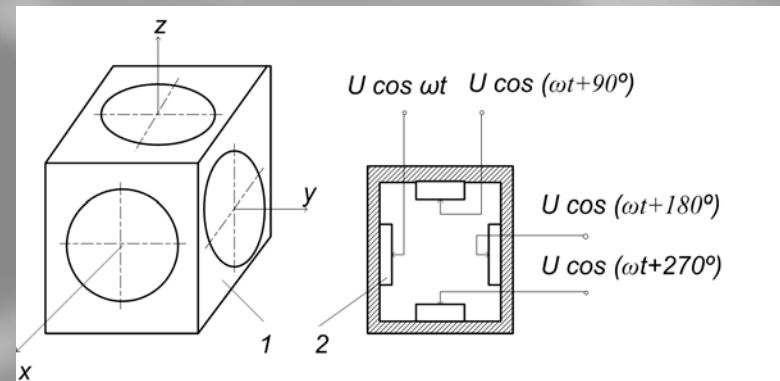
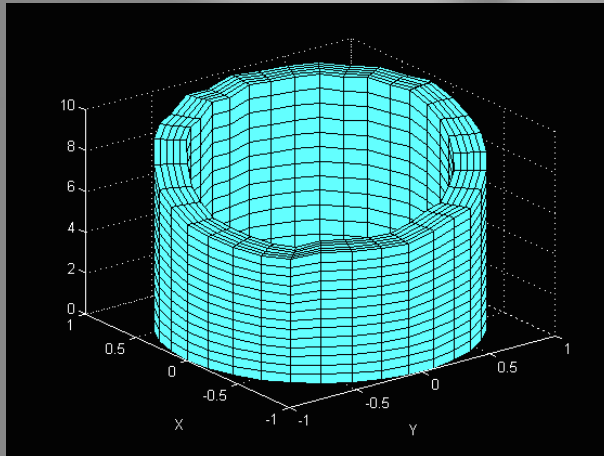

Consortium

- Main project partners – Kaunas University of Technology and Space Science and Technology Institute;
- The teams available at both institutions are highly competent both at piezo drives development (KTU) and in development of spacecraft attitude control instrumentation.

Consortium

➤ Wanted partners / competencies:

1. Organisation working in field of attitude control instrumentation and software;
2. Organisation working on development or production of piezo drives.

Contact and further information

- Space Science and Technology Institute
- Sauletekio av. 15, LT-10224 Vilnius, Lithuania
- cell: +370 685 67 977 fax: +370 5 2101249
- doibr@kmti.lt, domka@ktv.lt
- www.kmti.lt